

## To Cite This Article

Mr. Sainath M. Kadam, & Ms. Apeksha Choudhary. (2026). Renewable Energy–Based Electric Vehicle (EV) Charging Infrastructure: Solar/Wind Integrated Systems for Sustainable Transportation. *International Journal of Multidisciplinary Academic Studies and Research (IJMASR)*, 1(4), 269–278. <https://doi.org/10.5281/zenodo.20345293>

## Article Info

Received: 25<sup>th</sup> April 2026, Accepted: 27<sup>th</sup> April 2026, Published: 30<sup>th</sup> April 2026.

# Renewable Energy–Based Electric Vehicle (EV) Charging Infrastructure: Solar/Wind Integrated Systems for Sustainable Transportation

Mr. Sainath M. Kadam <sup>1</sup>, Ms. Apeksha Choudhary <sup>2</sup>

<sup>1</sup> Research Scholar, Civil Engineering Department, G H Raisoni University, Amravati, Maharashtra, India

<sup>2</sup> Assistant Professor, Civil Engineering Department, G H Raisoni University, Amravati, Maharashtra, India

**Abstract-** The rapid growth of electric vehicles (EVs) has created a strong need for efficient and sustainable charging infrastructure. Conventional EV charging systems mainly depend on grid electricity, which is largely generated from fossil fuels, leading to environmental pollution and increased carbon emissions. To overcome this problem, the present study focuses on the development of a renewable energy–based EV charging system using solar and wind energy. In this project, a hybrid system is designed by integrating solar photovoltaic (PV) panels and a wind turbine to generate electrical energy. The generated energy is stored in a battery and used for EV charging through an inverter system. A DC-DC boost converter is used to step up the voltage, while an MPPT controller ensures maximum power extraction from the solar panel. The system also includes an Arduino-based control unit for monitoring and managing voltage, current, and charging operations. Additional components such as LCD display, sensors, and switching devices are used for real-time monitoring and efficient control. The performance of the proposed system is analyzed under different weather conditions such as sunny, partially cloudy, and windy scenarios. The results show that the hybrid system is capable of maintaining a continuous and stable power supply by balancing energy generation and load demand. The system also ensures a regulated DC bus voltage and efficient utilization of renewable energy sources. The study concludes that the solar-wind hybrid EV charging system is a reliable, eco-friendly, and cost-effective solution for future transportation needs. It reduces dependency on fossil fuels, minimizes environmental impact, and supports sustainable development. The system is suitable for both urban and remote areas and has strong potential for large-scale implementation with further research and technological advancements.

**Keywords:** Electric Vehicles, Solar Energy, Wind Energy, EV Charging Station, Renewable Energy, Sustainable Transportation.

Advancing Knowledge Across Disciplines

## I. INTRODUCTION

The concept of transportation has undergone a significant transformation over the past few decades. Traditionally, transportation systems have been dominated by vehicles powered by internal combustion engines (ICE), which rely on fossil fuels such as petrol and diesel. While these vehicles have played an important role in economic development and mobility, they have also contributed heavily to environmental degradation. The burning of fossil fuels releases harmful gases such as carbon dioxide (CO<sub>2</sub>), carbon monoxide (CO), nitrogen oxides (NO<sub>x</sub>), and particulate matter, which lead to air pollution, global warming, and serious health issues. With the rapid growth of urbanization and industrialization, the number of vehicles on roads has increased drastically. This has resulted in higher fuel consumption, increased traffic congestion, and rising emission levels. According to various environmental studies, the transportation sector alone contributes a major percentage of total greenhouse gas emissions globally. In India, the situation is becoming more critical due to the increasing population and rising demand for personal and commercial vehicles. To address these environmental challenges, there has been a global shift towards sustainable and eco-friendly transportation systems. Electric Vehicles (EVs) have emerged as one of the most promising alternatives to conventional vehicles. EVs operate on electric energy stored in batteries and do not produce tailpipe emissions, making them environmentally friendly. Additionally, EVs are more energy-efficient and require less maintenance compared to traditional vehicles.

However, the adoption of EVs is not without challenges. One of the major issues is the availability and efficiency of EV charging infrastructure. For EVs to become widely accepted, a strong and reliable charging network is essential. Currently, most EV charging stations are connected to the electrical grid. Although this provides convenience, it raises another important concern. The electricity supplied by the grid is still largely generated from fossil fuels such as coal and natural gas. As a result, the indirect emissions associated with EV charging reduce the overall environmental benefits of electric vehicles. As discussed in your project work, even though EVs themselves are clean, the source of electricity used for charging plays a crucial role in determining their sustainability. If EVs are charged using non-renewable energy sources, they still contribute to environmental pollution indirectly. Therefore, it is essential to integrate renewable energy sources into EV charging infrastructure. Renewable energy sources such as solar energy and wind energy are considered the most suitable alternatives for sustainable power generation. Solar energy is abundantly available, especially in countries like India, which receive high solar radiation throughout the year. Wind energy is another important renewable source that can generate electricity depending on wind conditions. Both these energy sources are clean, renewable, and environmentally friendly.

However, each renewable energy source has its own limitations. Solar energy is available only during daytime and is affected by weather conditions such as clouds and rainfall. Wind energy, on the other hand, is unpredictable and varies depending on geographical location and seasonal changes. Due to these limitations, relying on a single renewable source may not provide a continuous and reliable power supply. To overcome this issue, hybrid energy systems have been developed. A hybrid system combines two or more energy sources to ensure a continuous and stable power supply. In the context of EV charging infrastructure, a hybrid solar-wind system is highly effective.

Solar energy can be utilized during daytime, while wind energy can supplement power generation during low solar conditions or at night. Additionally, energy storage systems such as batteries are used to store excess energy and supply power when required. The development of hybrid renewable energy-based EV charging systems also involves advanced technologies such as power electronics, energy management systems, and smart control strategies. These systems help in optimizing energy utilization, reducing energy losses, and improving overall efficiency. For example, Maximum Power Point Tracking (MPPT) techniques are used in solar systems to extract maximum power from solar panels. Similarly, control systems are used to manage energy flow between different components such as solar panels, wind turbines, batteries, and the grid. Another important aspect of EV charging infrastructure is the design of charging stations. Charging stations can be designed using different architectures such as AC bus systems and DC bus systems. In AC systems, multiple power conversion stages are required, which increases energy losses and reduces efficiency.

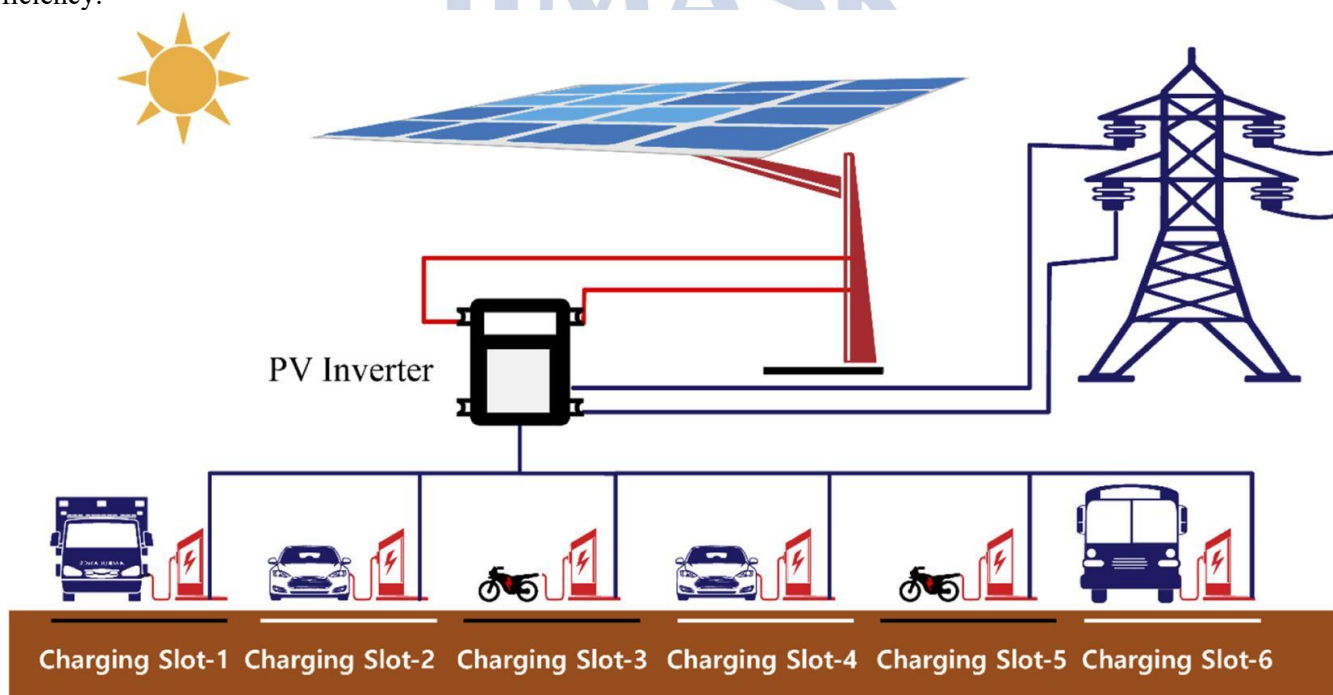

Figure 1.1: Renewable Energy-Based EV Charging Concept

## II. RESEARCH METHODOLOGY

### BLOCK DIAGRAM:

The block diagram of the proposed renewable energy-based electric vehicle (EV) charging system represents the overall structure and working arrangement of different components used in the system. It shows how energy flows from various sources such as solar panels and wind turbines to the electric vehicle through different stages like conversion, storage, and control. In this study, the system is designed as a hybrid renewable energy-based EV charging system, which integrates solar energy, wind energy, battery storage, and a control unit (Arduino). The block diagram helps in understanding how each component is connected and how they work together to provide continuous and efficient power supply for EV charging.

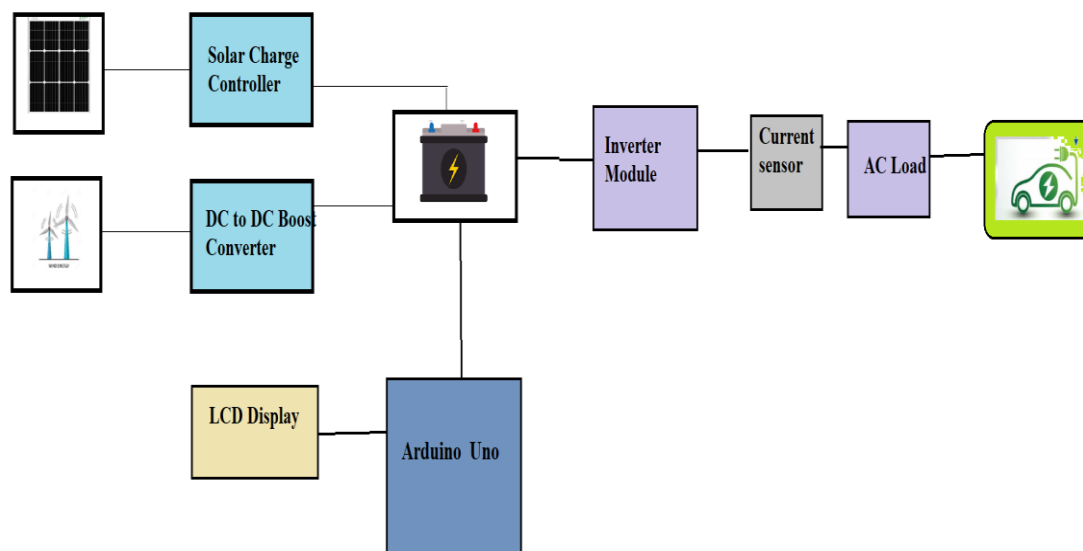

Figure 3.1: Block Diagram of Hybrid EV Charging System

The main components shown in the block diagram are explained below:

#### 1. Solar Panel (PV System)

Solar panels convert sunlight into electrical energy using photovoltaic effect. The generated power is in DC form and is used as a primary energy source during daytime. The output depends on solar radiation and panel efficiency.

#### 2. Wind Turbine (Dynamo)

The wind turbine generates electricity from wind energy. It acts as a secondary energy source and supports the system when solar energy is not sufficient. The dynamo converts mechanical energy of wind into electrical energy.

#### 3. Charge Controller

The charge controller regulates the voltage and current coming from solar panels and wind turbine. It prevents overcharging and deep discharging of batteries, thereby protecting the battery and improving its life.

#### 4. Battery Storage System

Battery is used to store excess energy generated from renewable sources. This stored energy is used during night time or when renewable generation is low. In this system, two separate batteries are used for better energy management and flexibility.

#### 5. Arduino Control Unit

Arduino is used as a control system to monitor battery voltage and manage charging operations. It continuously checks battery voltage and controls power flow accordingly.

#### 6. Inverter

The inverter converts DC power stored in battery into AC power if required for charging or load operation.

## 7. EV Charging Unit

This is the final output unit where electric vehicles are charged using the available power from the system.

### WORKING OF THE SYSTEM:

The working of the proposed system is based on the integration of renewable energy sources with intelligent control using Arduino. The system operates in a continuous cycle to ensure efficient energy utilization and safe charging. In this system, an Arduino microcontroller board is used as the main control unit. The primary function of Arduino is to monitor the battery voltage and control the charging process accordingly. Since the Arduino cannot directly handle high voltage (such as 12V from the battery), a voltage divider circuit is used to reduce the battery voltage to a safe level. The voltage divider circuit reduces the battery voltage from 12V to approximately 4V, so that it can be safely read by the Arduino analog input pins. This means that the Arduino reads a scaled value where 1V corresponds to 3V actual battery voltage. Based on this scaling, the Arduino calculates the actual battery voltage. The system is programmed in such a way that it continuously monitors the battery voltage level. A minimum threshold voltage of 8V (which corresponds to approximately 2.66V at Arduino input) is set. When the battery voltage drops below this level, the system stops supplying power to the EV charging unit to prevent deep discharge of the the battery. Instead of allowing further discharge, the system diverts the available renewable energy to recharge the battery. The charging process continues for a fixed duration of 1 hour, after which the system again checks the battery condition. This process is continuous and periodic, ensuring proper battery management and system stability. The use of two separate batteries in the system provides additional advantages. It allows better load distribution and flexibility in using different energy sources. For example, one battery can be charged using solar energy while the other is charged using wind energy (dynamo). This improves system reliability and ensures continuous power availability. A 12V, 10A charger is used in the system to enable faster charging of the battery. Higher current rating ensures that the battery can be charged quickly, which is important for maintaining continuous operation of the EV charging system.

### III. CIRCUIT DIAGRAM AND IT'S WORKING

#### CIRCUIT DIAGRAM:

The circuit diagram of the proposed solar-wind hybrid electric vehicle (EV) charging system represents the electrical connections between different components such as solar panel, wind turbine, battery, Arduino controller, inverter, and load. This diagram is very important because it shows how electrical energy flows through the system and how different components are interconnected for proper operation.

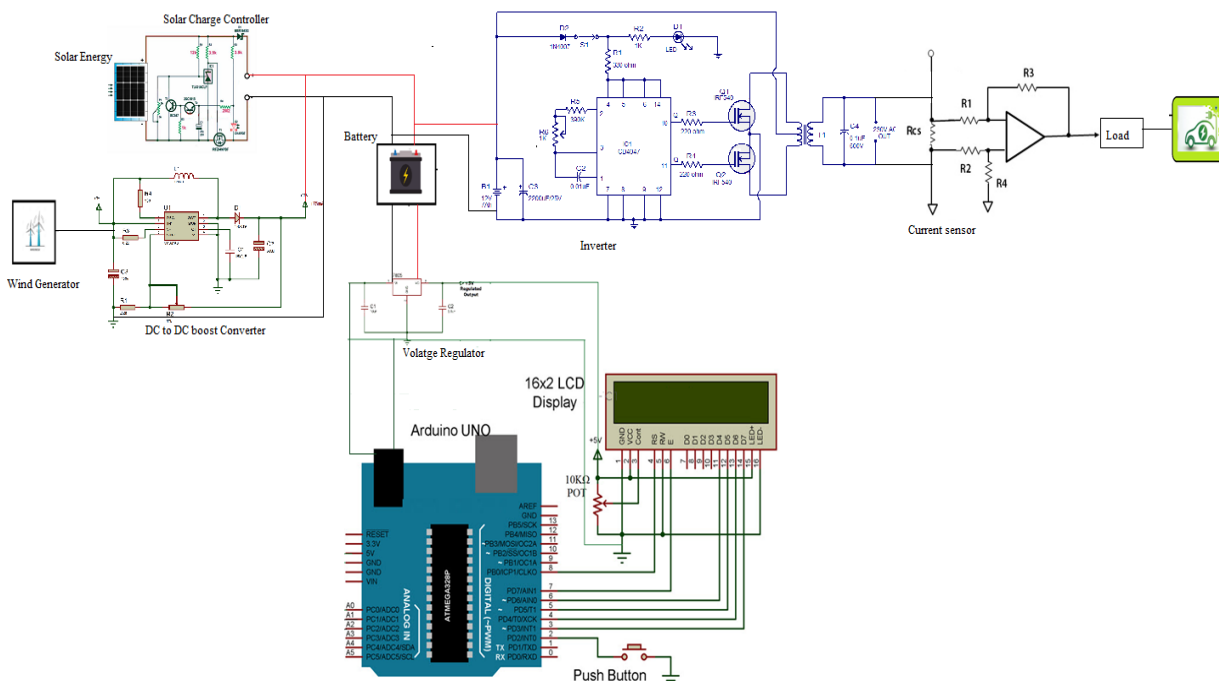

Figure 4.1: Circuit Diagram of Wind and Solar Based EV Charging System

### Description of Circuit Diagram:

*The circuit diagram mainly consists of the following parts:*

1. Solar panel circuit
2. Wind turbine circuit
3. Battery storage circuit
4. Voltage sensing circuit
5. Arduino control circuit
6. Inverter circuit
7. Load (EV charging unit)

All these components are electrically connected to ensure smooth flow of power and proper control of the system.

### Main Circuit Components:

#### 1. Solar Panel Circuit

The solar panel generates DC voltage when exposed to sunlight. This voltage is regulated using a charge controller before being supplied to the battery.

#### 2. Wind Turbine Circuit

The wind turbine generates electricity using wind energy. Since the output may vary, a rectifier and DC-DC converter are used to stabilize the voltage.

#### 3. Battery Circuit

A 12V battery is used to store energy from both solar and wind sources. It acts as a backup power source and ensures continuous supply.

#### 4. Voltage Divider Circuit

Since Arduino cannot handle high voltage, a voltage divider is used to reduce battery voltage to a safe level (0–5V range) for monitoring.

#### 5. Arduino Control Circuit

Arduino reads the voltage values and controls the charging and discharging process based on programmed logic.

#### 6. Inverter Circuit

The inverter converts DC power from battery into AC power required for EV charging.

#### 7. Load Circuit (EV)

The final output is supplied to the EV or AC load for charging.

### WORKING OF THE CIRCUIT:

The working of the solar-wind hybrid EV charging system is based on the combined operation of renewable energy sources and intelligent control using Arduino. The system ensures efficient energy generation, storage, and utilization. In this model, the power generated from solar panel (50W) and wind turbine (5W) is used to charge a 12V battery, which acts as the main energy storage unit. The stored energy is then used to supply power to the load (electric vehicle) through an inverter. Initially, when sunlight is available, the solar panel generates DC power. This power is passed through a charge controller to regulate voltage and protect the battery from overcharging. At the same time, the wind turbine generates electrical energy depending on wind speed. This energy is also regulated and combined with solar output to charge the battery.

*The generated power from both sources is continuously monitored. The system measures:*

1. Voltage of solar panel
2. Voltage of wind turbine
3. Battery voltage
4. Load current

These values are measured precisely using sensors and Arduino.

The Arduino microcontroller plays a key role in system operation. It reads the battery voltage using a voltage divider circuit. Since Arduino operates at a maximum of 5V, the 12V battery voltage is scaled down to a safe level. Based on this reading, Arduino decides whether to allow charging or discharging.

If the battery voltage is above the required level, the system allows power to be supplied to the load (EV). If the battery voltage drops below a certain threshold, the system stops supplying power to the load and starts charging the battery again. This prevents battery damage and ensures longer battery life.

The stored DC power in the battery is converted into AC power using an inverter.

**The inverter produces:**

1. Output Voltage = 230V AC ( $\pm 10\%$ )
2. Frequency = 50 Hz
3. Waveform = Sine wave

This AC power is suitable for charging electric vehicles.

**Working of Wind Turbine (Aerodynamic Concept):**

The wind turbine used in the system is a drag-type turbine, which consists of two or three scoops. When viewed from the top, it appears like an "S" shape.

1. When wind strikes the turbine, one side experiences more drag than the other
2. This difference in drag force causes rotation
3. The rotating shaft drives the generator to produce electricity

**However, drag-type turbines are less efficient compared to lift-type turbines because:**

1. They extract less energy from wind
2. Operate at lower speeds
3. Energy generation is limited

Also, since the turbine is placed at a lower height, wind speed is less, which reduces overall efficiency.

**System Specifications:**

**Table 4.1: System Specifications**

Parameter	Value
PV Array Power	50 W
Wind Turbine Power	5 W
System Voltage	12 V
Battery	12 V
Inverter Rating	25 VA
Output Voltage	230 V AC
Frequency	50 Hz
Waveform	Sine Wav

#### IV. RESULTS AND DISCUSSION

**Table 6.1: System Specifications**

Parameter	Value
PV Array Power	50 W
Wind Turbine Power	5 W
System Voltage	12 V
Battery	12 V
Inverter Rating	25 VA
Output AC Voltage	210 V ( $\pm 10\%$ )
Output Frequency	50 Hz

#### Experimental Readings:

The performance of the system was observed at different times of the day. The output of solar panel, wind generator, inverter, and load was measured.

**Table 6.2: Experimental Results**

Sr. No.	Time	Current (A)	PV Voltage (V DC)	Wind Voltage (V DC)	Inverter Input (V DC)	Inverter Output (V AC)	Load (W)
1	9 AM	0.89	10.1	3.2	13.2	187	9
2	12 PM	0.67	13.3	2.3	13.3	187	9
3	3 PM	0.68	13.1	2.6	13.3	187	9

#### Result Analysis:

From the above table, the following observations are made:

- At 12 PM, solar panel voltage is maximum (13.3V) due to peak sunlight.
- At 9 AM, wind contribution is slightly higher compared to afternoon.
- The inverter output remains almost constant (~187V AC), showing stable operation.
- The load is constant (9W), indicating controlled output supply.

#### ANALYSIS METHOD:

To evaluate system performance, different analysis tools and methods are used.

##### A. Wind Grapher

Wind Grapher is a software tool used for analyzing wind data. It processes raw wind data and generates graphs for:

- Wind speed variation
- Wind direction
- Data quality analysis

It helps in understanding wind availability and suitability for power generation.

##### B. HOMER Software

HOMER (Hybrid Optimization Model for Electric Renewable) is a powerful simulation tool used for designing hybrid energy systems.

##### Functions:

- Simulates renewable energy systems
- Performs cost analysis
- Optimizes system design
- Evaluates on-grid and off-grid systems

**Solar Analysis:**

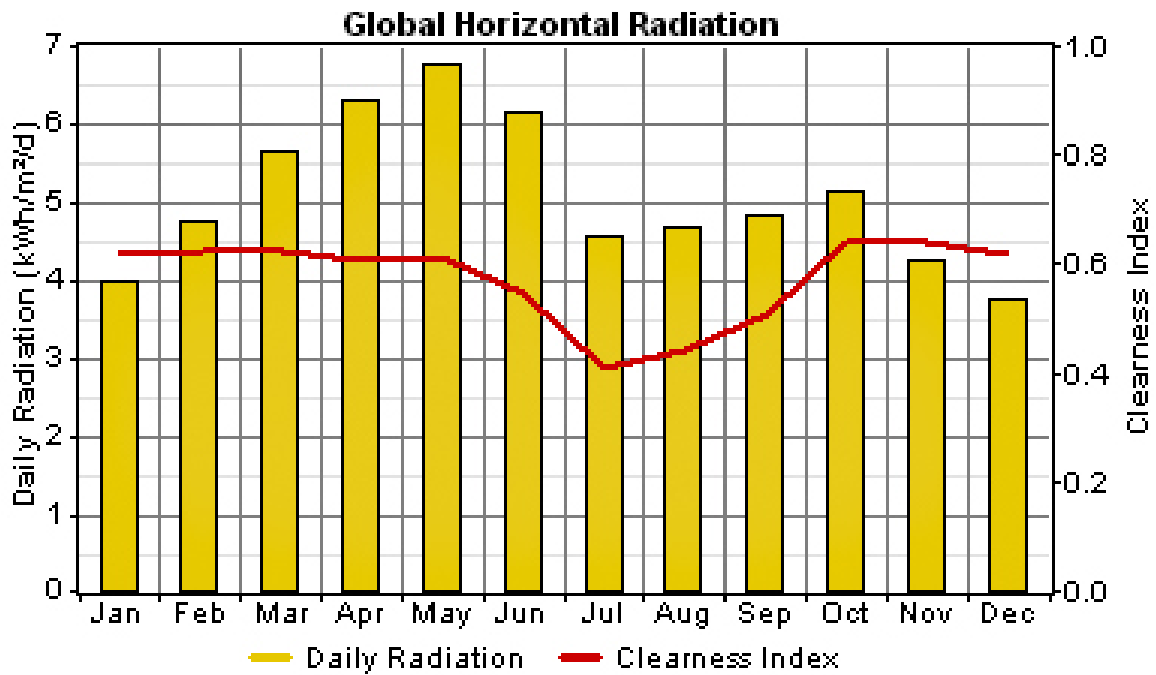

**Figure 6.1(a): Average Solar Radiation**

**Wind Speed Analysis:**

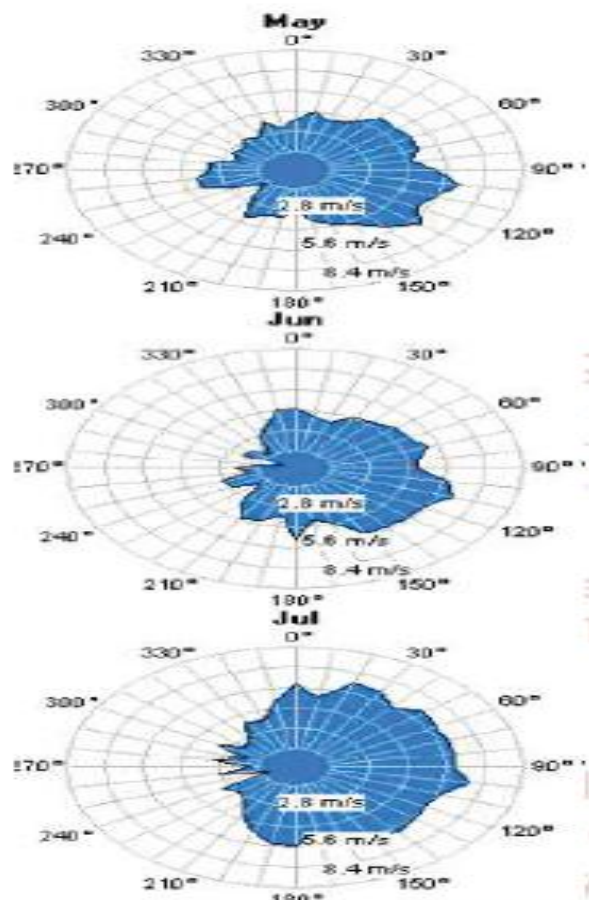

**Figure 6.1(b): Average Wind Speed Analysis**

## CONCLUSION

The present project on renewable energy-based electric vehicle (EV) charging infrastructure using solar and wind energy provides a clear understanding of how hybrid energy systems can be effectively used for sustainable transportation. The study demonstrates that combining solar photovoltaic (PV) systems with wind energy systems helps to overcome the limitations of individual renewable sources and ensures a continuous and reliable power supply for EV charging. From the overall work, it is observed that the proposed solar-wind hybrid charging system is a practical, efficient, and future-ready solution for EV charging stations. One of the major advantages of this system is its ability to provide uninterrupted power supply even when one energy source is not available; for example, solar energy is dominant during daytime, while wind energy supports the system during night time or cloudy conditions, thereby improving reliability and ensuring continuous charging. The system also offers flexibility by supporting battery operation with renewable energy sources, which is particularly useful during maintenance or repair, ensuring minimum downtime in charging stations. The performance of the system has been analyzed under different real-time scenarios, including variations in weather conditions such as sunny, partially cloudy, and cloudy days, as well as different EV loading conditions over a 24-hour period. The results indicate that the energy balance between generation (solar and wind) and load demand is effectively maintained, ensuring efficient utilization of available energy. Additionally, the system successfully maintains a stable and regulated DC bus voltage through an efficient energy management and control strategy. The Arduino-based control system continuously monitors parameters like voltage and current and takes appropriate decisions for charging and discharging, ensuring safe and reliable operation.

## REFERENCES

- [1] R. Kassem, A. M. El-Rifaie, A. A. F. Youssef, A. Y. Abdelaziz, S. A. Mohamed, and H. Saleeb, "Design and optimal sizing of PV/grid-integrated EV charging stations at universities: A case study," *Unconventional Resources*, vol. 8, 2025, Art. no. 100213, doi: 10.1016/j.uncres.2025.100213.
- [2] S. Saini and D. Chanda, "Optimization of electric vehicles charging stations in urban areas: A Huff model and genetic algorithm study of Chandigarh, India," 2025.
- [3] A. Karmakar, P. K. Sadhu, S. Das, S. P. Bihari, B. Khan, and A. Ali, "Techno-economic analysis and optimized PV-powered EV charging facilities under various climate conditions in India," *Discover Sustainability*, vol. 6, 2025.
- [4] M. M. Elkholy, A. Abd El-Raouf, M. A. Farahat, and M. E. Lotfy, "Design and techno-economic feasibility study of a solar-powered EV charging station in Egypt," 2025.
- [5] A. K. Tripathi et al., "Integration of solar PV panels in electric vehicle charging infrastructure: Benefits, challenges, and environmental implications," *Energy Science & Engineering*, 2025, doi: 10.1002/ese3.70014.
- [6] J. A. Guerrero-Silva, J. I. Romero-Gelvez, A. J. Aristizábal, and S. Zapata, "Optimization and trends in EV charging infrastructure: A PCA-based systematic review," *World Electric Vehicle Journal*, 2025.
- [7] K. S. P. Oruganti et al., "An integrative review of standalone solar powered EV charging stations: Standards, policies, design aspects, and future directions," *Energy Reports*, vol. 14, pp. 2893–2913, 2025, doi: 10.1016/j.egy.2025.09.005.
- [8] M. Albaba, M. Pierce, and B. Yeşilata, "A real-world case study of solar PV integration for EV charging and residential demand in Ireland," 2025.
- [9] A. K. Pampana, S. Yoon, and H. Yates, "Sustainable design of electric vehicle charging station: Solar district," in *Proc. ASC Int. Conf.*, 2025.
- [10] M. H. Alsharif, F. Alsaif, M. K. Singla, S. Manna, and M. K. Kim, "Techno-economic optimization and environmental analysis of a solar-powered EV charger system," *Energy Reports*, vol. 13, pp. 5803–5814, 2025, doi: 10.1016/j.egy.2025.05.040.
- [11] M. Alaamri et al., "EV-based solar charging station: A study for economical design," *American Journal of Vehicle Design*, vol. 8, no. 1, pp. 1–6, 2025, doi: 10.12691/ajvd-8-1-1.
- [12] B. Mohan, M. V. Ramesh, M. Seshu, P. M. Kumar, and M. Valavala, "Design and implementation of EV charging station integrated with different energy sources using ANFIS controller," 2025.
- [13] A. Mouelhi, Y. Kraiem, and M. F. Mimouni, "Optimization of PV benefits for EV charging stations using deterministic and fuzzy inference system methods," *Journal of Engineering Research*, 2025, doi: 10.1016/j.jer.2024.10.018.
- [14] H. M. V. Nguyen, N. N. To, T. A. Tran, and H. T. Nguyen, "Designing solar-powered EV charging stations for future green cities," 2024.
- [15] Z. S. Joseph, C. A. Anosike, and B. A. Adegboyega, "Optimizing sustainable urban mobility: Integration of EV charging infrastructure into smart buildings," 2024.

- [16] R. V. Patel and N. N. Ghuge, "Design and simulation of renewable energy integrated EV charging infrastructure with predictive energy management," 2024.
- [17] D. Chaudhari, A. Yadav, A. Nehete, P. Patil, and V. A. Shendkar, "Smart EV charging station using hybrid power generation system," IJRSET, 2024, doi: 10.15680/IJRSET.2024.1304369.
- [18] A. Naseri, A. R. Araghi, M. Razeghi, and Y. Noorollahi, "Systematic site selection of solar-powered EV charging stations," Energy Strategy Reviews, vol. 56, 2024, Art. no. 101596, doi: 10.1016/j.esr.2024.101596.
- [19] P. Singla et al., "Design and simulation of 4 kW solar power-based hybrid EV charging station," 2024.
- [20] M. Dudi et al., "Optimizing solar powered charging stations for EVs: Integration of fast and slow charging," 2024.
- [21] H. Rashid et al., "A comprehensive review on PV-based EV charging infrastructure," 2024.
- [22] S. N. Manikyalarao, M. S. Babu, and N. Venkataramana, "Design of hybrid wind and solar powered charging station," 2023.
- [23] M. A. Sahin and U. Kurt, "Design and optimization of grid-supported solar vehicle charging stations," Journal of Engineering Research and Applied Science, vol. 12, no. 1, 2023.
- [24] P. Anaji, A. K. N., S. R. S., S. Anjum, and D. L. R., "Development of solar-based electric vehicle charging station," 2023.
- [25] A. Shafiq et al., "Integration of solar-based charging station in power distribution network," 2023.
- [26] S. A. Yonis et al., "Designing a solar PV-battery based EV charging station," IJEIR, 2023, doi: 10.47933/ijeir.1231500.
- [27] S. Reddy et al., "Design and development of EV charging station with solar power," 2023.
- [28] A. Shafiq et al., "Solar PV-based EV charging station for security bikes," Sustainability, 2022.
- [29] K. L. Mokariya, "Solar PV based EV charging in India: Startup ecosystem analysis," Advances in Dynamical Systems and Applications, 2022.
- [30] S. S. Ambavane, S. R. Bhoir, S. S. Pimpare, and P. A. Kulkarni, "Designing of solar charging stations for EVs," 2021.
- [31] A. Singh et al., "Design and analysis of solar-powered EV charging station for Indian cities," 2021.
- [32] G. R. Riful, P. Sarker, S. H. Shawon, and M. M. Hasan, "Design of a photovoltaic-based EV charging station," B.Sc. thesis, Brac Univ., 2021.



**IJMASR**

International Journal of Multidisciplinary  
Academic Studies and Research

*Advancing Knowledge Across Disciplines*